

Connecting a secondary Air-Assist source...

This tutorial is for guiding the laser machine owner in adding a higher power air control system for the nozzle air assist. A stronger air assist can help clear the kerf of debris from engraving that material.

Jumper settings on the motion controller board:

The JP1 is related to signal input voltage level. The board should be set for input signals that are 24VDC.

This jumper should connect pins 1 and 2. The JP2 is related to analog or PWM control of the Laser power supply.

The connector for JP2 should be set for analog control with connection to Pins 1 and 2. Do not change the JP2 position. The JP3 is related to output signals at connector Y1. For devices that are 24VDC, we need to connect the jumper to connect pins 1 and 2.

The Y1 connector is used for output signals. The pin 1 is used for controlling the air assist valve. The "Air-Assist" signal is active when the project is running. If the "Pause" feature is selected, then the "Air-Assist" remains active. If the "Stop" button is pressed, then the "Air-Assist" signal is de-activated.

The 6515 motion controller uses a ULN2803 driver chip to provide power for the "Air-Assist" signal. The driver chip is limited for amperage and is designed to be a current collector. The relay or other device must be wired as a sinking configuration. The relay must be wired for the positive side of the relay to be connected to Pin 6 of the Y1 connector. The negative (A2) connector of the relay must be connected to Pin 1 of the Y1 connector.

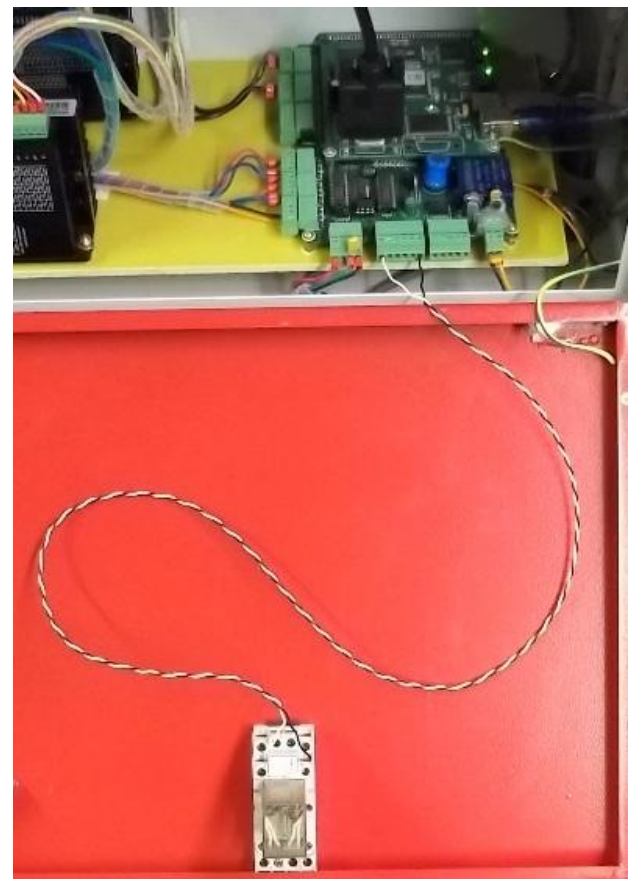

NOTE:

Selecting your relay is important. The relay must be 24VDC and consume less than 100mA with at least one set of normal-open contacts. Examples of proper relays would be Allen Bradley 700-HLT12Z24, Idec RQ2V-CM-D24 or RY2S-ULCDC24, or Omron G2RL series... Make sure to also purchase the relay socket with your relay. You can also purchase a relay that mounts directly to the panel, without a socket or DIN mount. Most any 24VDC general purpose relay with normal-open contacts will work. This is NOT a safety application and so the relay does NOT need to be of any excessive specifications. The control voltage and amperage is at a level that is intrinsically safe.

We recommend relay from Digikey.com with part number PB311-ND (center picture above). The price is only \$3.41. The relay can be screw-mounted directly to any flat surface. This relay also has tabs for using quick crimp connectors on your wires.

The 24VDC relay is used to control a larger voltage that will drive the air solenoid. The air solenoid will be the device that allows flow of the air from the building's air compressor. The solenoid will be electrically connected so that the relay uses the Normal-Open contacts to control when the solenoid is on. The solenoid should not allow air flow when it is off. Turning the solenoid on will open a valve that allows the air to pass through.

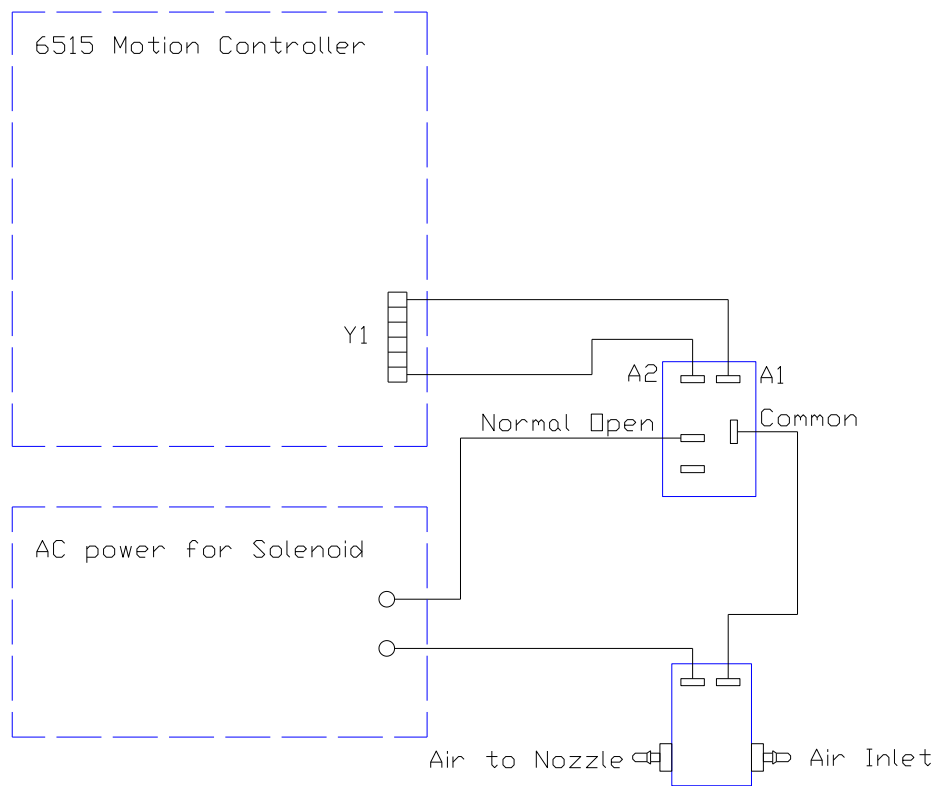

Connection Diagram

The following picture shows how we connected the air from our house compressor into the solenoid valve. We also included a bypass route with adjustment so that we could always have at least a small amount of air flow. (The black box wired to the solenoid is a capacitor used as a spark arrestor.. not required). Do NOT purchase a 24VDC solenoid and connect directly to the 6515 control board. Connecting a solenoid directly to the 6515 board will damage the motion control board. We recommend that you purchase a ½" brass 110VAC electric solenoid valve for air (normally closed). This type of valve can be found on ebay.com for near \$35.



The plastic pipe and fittings can be purchased at a local hardware store such as Lowes. This configuration uses (2) Tees, (2) adaptors for ½" pipe to ½ NPT thread, (2) Wall Mount elbows, (1) gate valve with glue fittings, and about 3 feet of CPVC pipe. We used a ¼" NPT tap to make threads for connecting the brass hose fittings.



The incoming air line should be prepared for the laser machine. The air must be clean and dry. There cannot be any water or dirt in the air line. The air pressure will need to be regulated to near 5PSI and a relatively low CFM. It is nice to have a pressure gage at the adjustment knob. If you use a filter on the regulator body, then be sure to use an air spinning type of filter with automatic drain. Do NOT use a desiccant or sintered style filter. Some regulators do not adjust pressure well at levels near 5 to 20 PSI. Be sure to get a regulator that is appropriate for the pressure and flow rate.

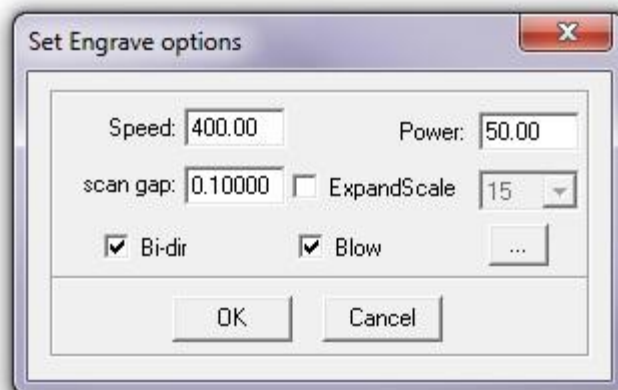
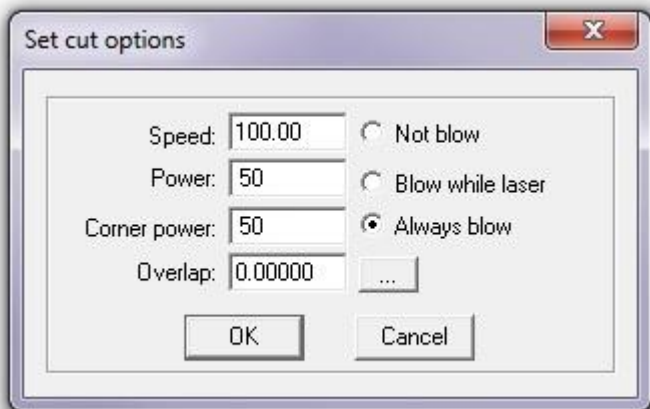

The final step in using the modified air assist system is to enable the software. The software features settings for enabling the “Blow Signal” during the lasering process. These selectable checkboxes can be found in the dialog boxes when setting the options of the Cut, Engrave, Grade Engrave, or Holes feature of each color layer.

